

**BASE 35**

# **Industrial Door Drive**

**Operator**

**Mechanical Installation And User Guide**

# CONTENTS

1. GENERAL SAFETY INFORMATION.....	1
2. TECHNICAL DATA.....	2
3. DIMENSION.....	3
4. PREPARATION.....	4
5. MECHANICAL INSTALLATION.....	5-6
6. OPERATION WITH RELEASE MECHANISM.....	7
7. COMPLETING COMMISSIONING / INSPECTION.....	8

## Symbols



**Warning** - Potential injury or danger to life!



**Warning** – Danger to life from electric current!



**Note** – Important information!



**Requirement** – Required action!

\* Schematic representations are based on product examples. Deviations from delivered products are possible.

# **1. GENERAL SAFETY INFORMATION**

## **Specified use**

The industrial door drives intended for a power-operated door with a control device.

The safe operation is only guaranteed with specified normal use. The drive unit is to be protected from rain, moisture and aggressive ambient conditions. No liability for damage caused by other applications or non-observance of the information in the manual.

Modifications are only permitted with the agreement of the manufacturer. Otherwise the Manufacturer's Declaration shall be rendered null and void.

## **Safety information**

Installation and commissioning are to be performed by skilled personnel only.

Only trained electrical craftsmen are permitted to work on electrical equipment. They must assess the tasks assigned to them, recognize potential danger zones and be able to take appropriate safety measures.

Installation work is only to be carried out with the supply off.

Observe the applicable regulations and standards.

## **Coverings and protective devices**

Only operate with corresponding coverings and protective devices.

Ensure that gaskets are fitted correctly and that cable glands are correctly tightened.

## **Spare parts**

Only use original spare parts.

## 2. TECHNICAL DATA

Model	BASE 35
Max. output torque (Nm)	35
Rated output torque (Nm)	25
Output speed (rpm)	24-32
Output shaft/hollow shaft (mm)	φ25.4
Static holding torque (Nm)	400
Door area (m <sup>2</sup> )	≤18
Input voltage (V)	110-127/220-240
Motor power (W)	350
Control system	24V DC
Thermal protection temperature (°C)	105
Max. cycles per hour (Cycle)	20
Class of protection	IP 54
Limit switch range (maximum revolutions of output shaft / hollow shaft)	15
Temperature range (°C)	-20 ~ +40 (+60)

\* When using a temperature range of +40°...+60°C use half of maximum cycles per hour.

### 3. DIMENSION

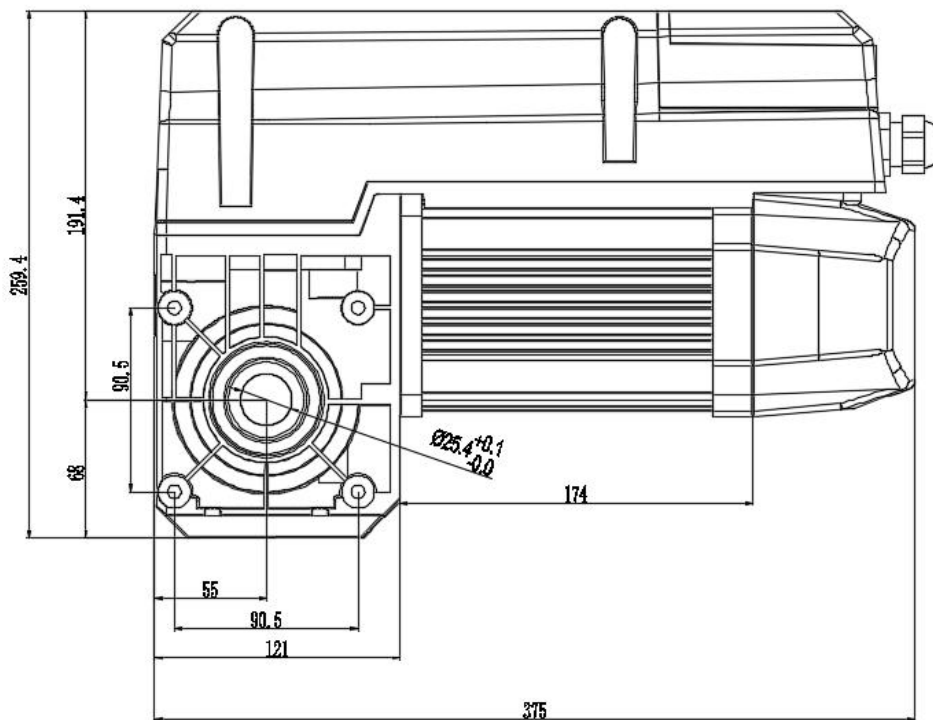
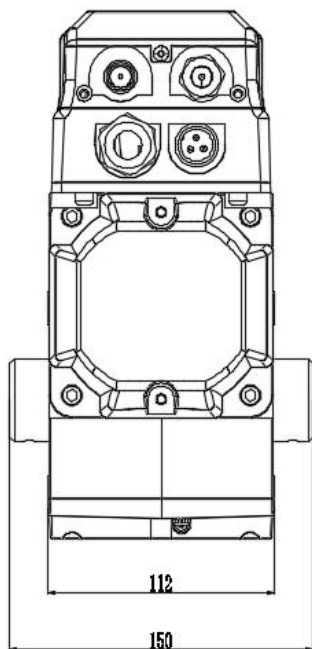

## 4. PREPARATION

### Danger!

To avoid injury, the following points must be observed:

- The operator must be installed free of any tension.
- The operator must not move on the shaft.
- The design and subsurface of all components must be suitable for the forces encountered.

### Warning!

To avoid damage to the operator and the door, the operator must only be fitted if

- the operator is undamaged,
- the ambient temperature is  $-20^{\circ}\text{C}$  to  $+60^{\circ}\text{C}$ .,
- the altitude of the location does not exceed 1,000 m,
- a suitable protection type has been selected.

Before installation, ensure that

- the operator is not blocked,
- the operator has been newly prepared after a lengthy storage period,
- all connections have been carried out correctly,
- the direction of rotation of the drive motor is correct,
- all motor protective devices are active,
- no other sources of danger exist,
- the installation site has been cordoned off over a wide area.

## 5. MECHANICAL INSTALLATION

### Connecting bolt:

- ▶ Hexagon flange bolts with a minimum strength of 800 N/mm<sup>2</sup> (8.8) must be used.

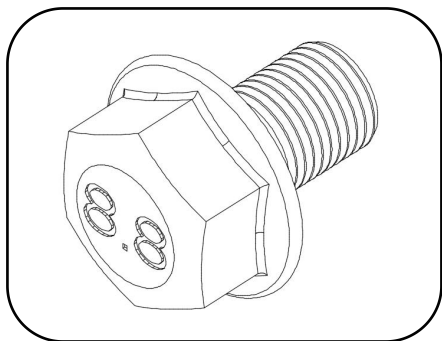

### Allowed installation location:

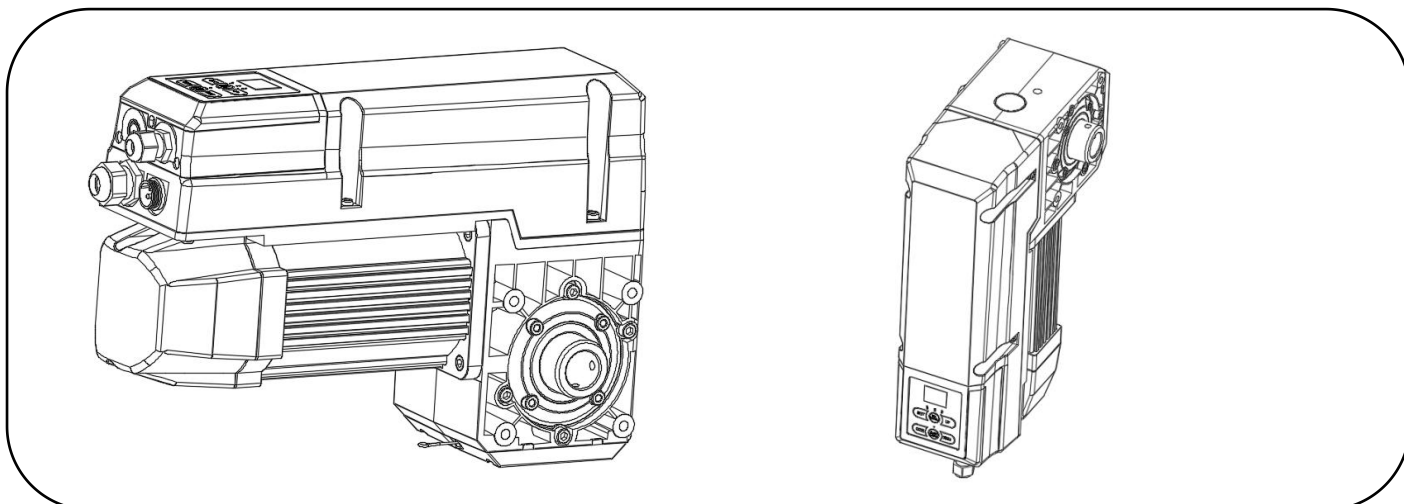

### Mounting the accessories:

- ▶ Use the provided connection components

1. M8\*12 hexagon flange bolts x 4;

2. M6 \* 10 Hexagon socket set screws x 4;

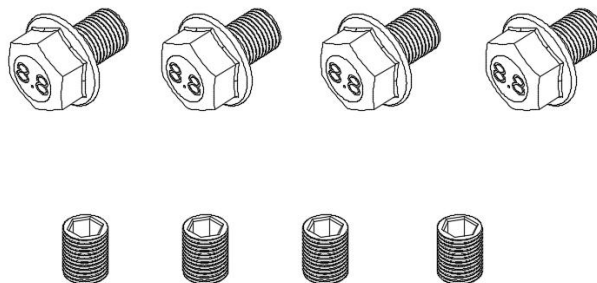

## Mounting with the torque support bracket:



### Warning!

To avoid damage to the operator and to the door, the operator must be mounted on a console or a torque support bracket so that it is vibration damped.

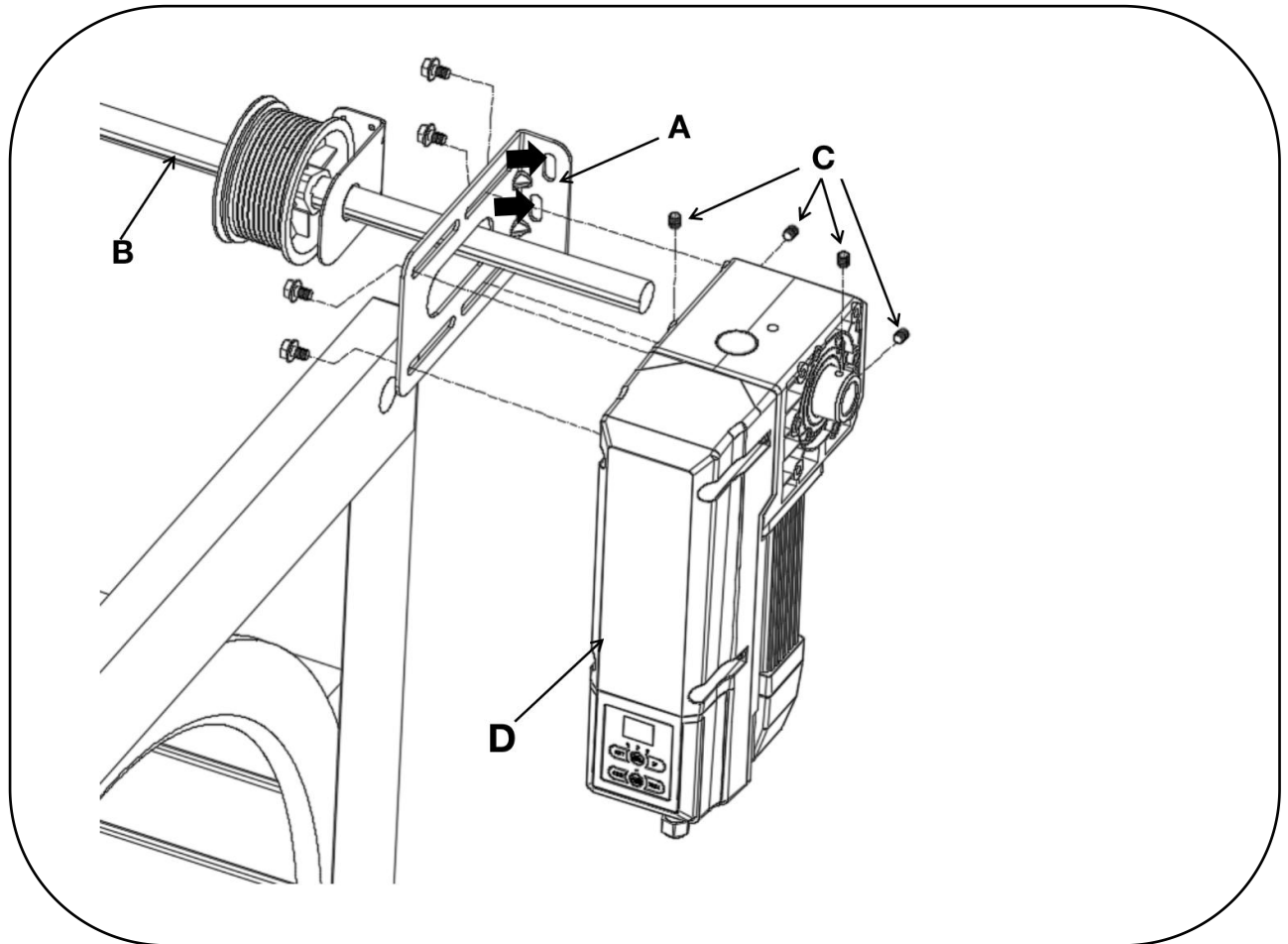

- ☞ Fit the torque support bracket/console (A).
- ☞ Grease the spring shaft (B) around the operator seating.
- ☞ Place the operator (D) on the spring shaft (B).
- ☞ Tighten the 4 x M6\*10 hexagon socket set screws (C) on the spring shaft (B) through the output shaft.
- ☞ Fix the operator to the torque support bracket with 4 screws.



## 6. OPERATION WITH RELEASE MECHANISM

The release mechanism enables the industrial door to be manually operated to disconnect the locked state between the output shaft and the operator in the event of a power failure or emergency.

- ▶ 1. Please install the equipped release extension cord to the release wire pull ring of the operator by yourself and make sure it is firm.
- ▶ 2. If the internal gear can't rotate freely, pull down the release handle to switch the operator to manual operation, so that the output shaft can be rotated manually.
- ▶ 3. After the operator is installed, the release handle should be about 1.8M above the ground and a warning sign should be posted nearby to prevent children's misoperation from causing personal injury and property loss.

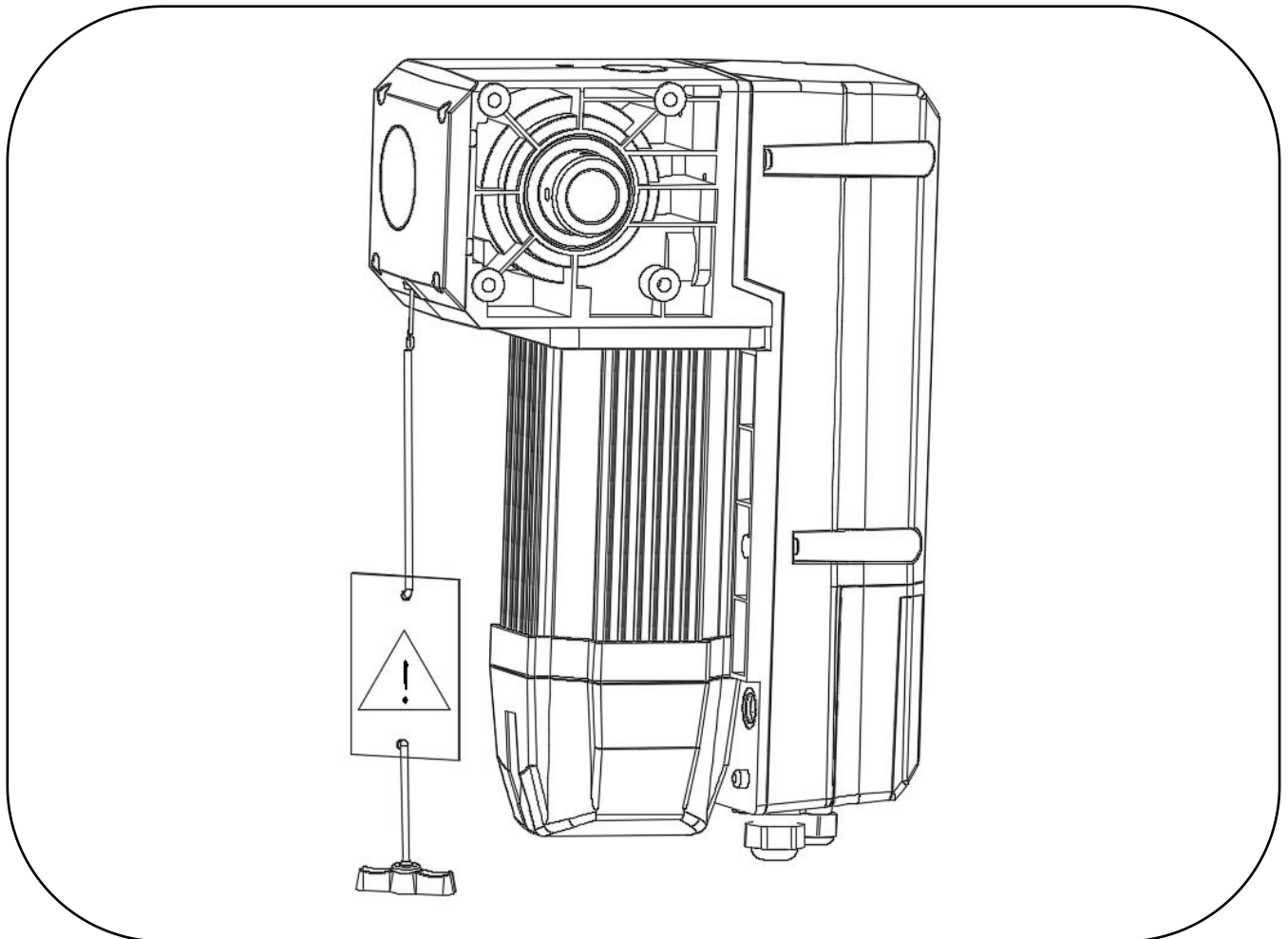

## **7. COMPLETING COMMISSIONING / INSPECTION**

Check the following components and then install all covers.

### Gearbox

Check the drive unit for loss of oil (a few drops can be neglected). Protect the output-shaft permanently against corrosion.

### Mounting

Check that all connection elements (consoles, torque mounts, screws, locking rings, etc.) are secure and in proper condition.

### Electrical wiring

Check the connection cables and cabling for damage or crushing. Check that the screw connections and plug connections are fitted properly with a good electric contact.

### Emergency manual operation

Check the function with the power disconnected. Perform the check only between the final limit positions.

### Limit switch

Check the final limit positions by opening and closing fully. The safety area must not be approached.

Date Version: 16/03/2021