

**BASE 35**

**Industrial Door Drive**  
**Control System**  
**Instructions And User Guide**

Version 1.6

# CONTENTS

1. GENERAL SAFETY INFORMATION.....	1
2. TECHNICAL DATA.....	2
3. OVERVIEW OF CONTROL.....	3
4. BASIC BUTTON INSTRUCTION .....	4
5. COMMON FUNCTION QUICK SETTING INSTRUCTION.....	5
6. QUICK SETTING TO GUIDE THE DRIVE WORKS BY "AAS".....	6-7
7. FUNCTION TABLE MENU ITEMS.....	8
8. FUNCTION MENU DESCRIPTION.....	9-27
9. FAULTS.....	28-29
10. TX/RX FUNCTION MODULE DESCRIPTION.....	30-31
11. FUNCTION WIRING DIAGRAM.....	31-36
12. DECLARATION OF INCORPORATION.....	37
13. DECLARATION OF CONFORMITY.....	37

# **GENERAL SAFETY INFORMATION**

## **Specified use**

The industrial door drives intended for a power-operated door with a drive unit. The safe operation is only guaranteed with specified normal use. The drive unit is to be protected from rain, moisture and aggressive ambient conditions. No liability for damage caused by other applications or non-observance of the information in the manual.

Modifications are only permitted with the agreement of the manufacturer. Otherwise the Manufacturer's Declaration shall be rendered null and void.

## **Safety information**

Installation and commissioning are to be performed by skilled personnel only. Only trained electrical craftsmen are permitted to work on electrical equipment. They must assess the tasks assigned to them, recognize potential danger zones and be able to take appropriate safety measures.

Installation work is only to be carried out with the supply off.

Observe the applicable regulations and standards.

**WARNING:** Important safety instructions.

- It is vital for the safety of people to follow all instructions. Keep this manual.
  - Do not let children play with the appliance or control devices including remote controls.
  - Follow all instructions, as incorrect installation can lead to serious injuries.
  - The actuating element of the dependent switch must be positioned so that it can be seen directly on the driven part, but out of reach of the moving parts. If it is not actuated by a key, it must be placed at a minimum height of 1.5 m and not accessible to the public;
- after installation, make sure that the mechanism is set correctly and that the protection system and any manual controls work properly.

## **Coverings and protective devices**

Only operate with corresponding coverings and protective devices.

Ensure that gaskets are fitted correctly and that cable glands are correctly tightened.

## **Weighted sound pressure emission level A of the motor**

LpA less than or equal to 70 dB (A).

**WARNING Z101** . - The effect of noise emitted by the structure, including the driven part to which the drive will be connected, is not considered.

## **Spare parts**





Only use original spare parts.

## TECHNICAL DATA







Model	BASE 35
Max. output torque (Nm)	35
Rated output torque (Nm)	25
Output speed (rpm)	24–32
Output shaft/hollow shaft (mm)	φ 25.4
Static holding torque (Nm)	400
Door area (m <sup>2</sup> )	≤18
Input voltage (V)	110–127/220–240
Motor power (W)	350
Control system	24V DC
Thermal protection temperature (° C)	105
Max. cycles per hour (Cycle)	20
Class of protection	IP 54
Limit switch range (maximum revolutions of output shaft / hollow shaft)	15
Temperature range (° C)	–20~+40 (+60)

# OVERVIEW OF CONTROL











	<p>Digital display:</p> <ul style="list-style-type: none"> <li>• The first boot up displays <b>FL</b>, then count down from <b>99</b> to <b>00</b>.</li> <li>• <b>--</b> : Without travel limit set.</li> <li>• <b>  </b> : With travel limit set.</li> </ul>
	<p>Button : UP/STOP</p>
	<p>Button : STOP</p>
	<p>Button: DOWN/STOP</p>

## BASIC BUTTON INSTRUCTION

Item	Button	Description
1.		<p><b>Short press:</b> Confirm setting;  <b>Long press:</b> Enter the function menu setting</p>
2.		<p><b>Short press:</b> Adjust the function menu  <b>Long press:</b> Restore factory setting</p>
3.		<p><b>Short press:</b> Adjust the function menu  <b>Long press:</b> Running cycle counter inquiry</p>
4.		<p><b>Short press:</b> Return  <b>Long Press:</b> Enter into rail system selection          (Refer to the quick operation guide for details – Page 6)</p>
5.		<p><b>Short press:</b> Quick activate “AUTO CLOSE” function</p>
6.		<p><b>Short press:</b> Quick activate “FORCE MARGIN” function</p>

## COMMON FUNCTION QUICK SETTING INSTRUCTION









Function Item	Operation	Description
AUTO CLOSE	Short press: 	<p><b>Important:</b> The "AUTO CLOSE" only can be activated when the Photo beam or light curtain has been correctly installed and the photo beam function has been enabled from function menu (Refer to page 18 – Menu 5).</p> <ul style="list-style-type: none"> <li>Short press the "AUTO CLOSE" button, when the indicator light is turned on. It means the "AUTO CLOSE" function has been activated.</li> </ul> <p>(Default: The door only can auto close while in the open limit position. And the Auto Close time is 15 seconds).</p> <p><b>Note:</b> Refer to page 16 – Menu 4 to change any setting for AUTO CLOSE conditions or time if necessary.</p> <p><b>Note:</b> If there is no any photo beam or light curtain installed, the door can not be closed, and the LED display will show the letter "E6" as an indication.</p> <ul style="list-style-type: none"> <li>Short press the "AUTO CLOSE" button, when the indicator light is turned off. It means the "AUTO CLOSE" function has been dis-activated.</li> </ul>
Force Adjustment	Short press: 	<ul style="list-style-type: none"> <li>Short press the button, the digital display will indicate the current force level firstly</li> <li>Continually short press the button: Incremental rolling display the force level between  to </li> </ul> <p>L1: Minimum force level ; L9: Maximum force level</p> <p><b>Note:</b> L3 to L7 is recommended.</p>
Running Cycle Counter Inquiry	Long press the button for 6 seconds: 	<ul style="list-style-type: none"> <li>The digital will rolling display  , it represents the drive has been 10 running cycles worked.</li> </ul> <p><b>Note:</b> The running cycles is displayed in 6 digits</p>
Restore Factory Setting	Long press the button for 10 seconds: 	<ul style="list-style-type: none"> <li>The digital will rolling display  , then release the button , it means the drive has been restored to factory setting.</li> </ul> <p><b>Note:</b> The running cycle counter record will not been cleared.</p>

# QUICK SETTING TO GUIDE THE DRIVE WORKS



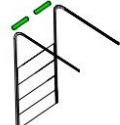

## BY "AAS" (Auto adaptive system)

**Important:**











- "AAS" will automatic identify the door condition to define a best program for its "Open/ Close speed", "Soft start/ soft stop ranges" and "Force sensitivity".
- A quick setting guide the drive will work properly after below operation.

<p>1.Long press :</p>  <p>over 3 seconds to enter into RAIL SYSTEM selection</p>	<p>All of the indicator lights are light up constantly for "SL,HL,VL" and then off.</p> <p>Then release the button until one of the indicator lights flashes.</p> 
<p>2.Short press :</p>  <p>to select the corresponded RAIL SYSTEM of the door .</p>	<p>The corresponded light flashes for "SL,HL,VL"</p>  <ul style="list-style-type: none"> <li>•  SL: Standard lift sectional doors with cylindrical cable drum</li> <li>•  HL: High lift sectional doors with cylindrical-conical cable drum</li> <li>•  VL: Vertical lift sectional doors with conical cable drum</li> </ul>
<p>3.Short press :</p>  <p>to confirm the selected Rail System</p>	<p>The corresponded indicator light is constant on for "SL,HL,VL"</p>  <p>Then, the digital display shows  to start the OPEN travel limit setting.</p>









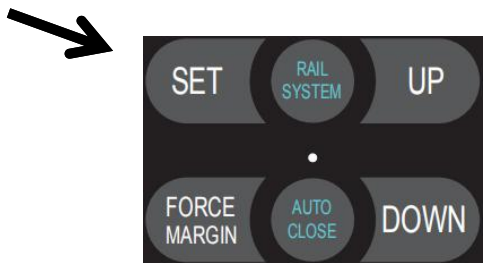

<p>4. Long press:</p> 	<p>Long press the button UP/DOWN to set the door to the target OPEN limit position, then release the buttons.</p> <p>Short Press the SET button once to store the open limit position, the digital displays  to start the CLOSE travel limit setting.</p>
<p>5. Long press:</p> 	<p>Long press the button UP/DOWN to set the door to the target CLOSE limit position then release the buttons.</p> <p>Short press the SET button once to store the CLOSE limit position, then the door drive will automatically open and close the door to store the door weight and spring balance conditions.</p> <p><b>Note:</b></p> <p>a. If a system selection error occurs during the setting process, please</p>  <p>click , Execute enter to exit the setting, and then execute the first operation again.</p> <p>b. Active or change any stand alone function, refer to the below "FUNCTION TABLE MENU".</p>

## FUNCTION TABLE MENU ITEMS

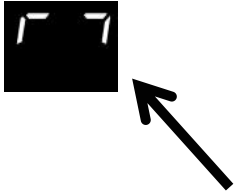
MENU	Function Table Menu	Status Indications
0	Travel Limit Setting	
1	Common Function Setting	
2	Operating Parameter Setting	
3	Soft Stop (during-operation) Function Setting	
4	AUTO CLOSE Time & Condition Setting	
5	Infrared Beam & Light Curtain Function	
6	Terminals for Extra Function Setting	
7	Courtesy Light Function Setting	
8	Maintenance Alarm Function Setting	
9	Gear Motor Running Direction Rotating Setting	

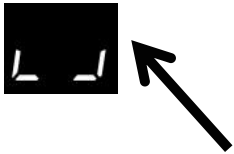
# FUNCTION MENU DESCRIPTION

**MENU 0  Travel Limit Setting**

		<ul style="list-style-type: none"> <li>● Press and hold SET button for about 6 seconds to enter travel limit setting until “0.—” appears on the display then release the button.</li> </ul>
		<ul style="list-style-type: none"> <li>● Press SET to enter travel limit setting menu, the digital displays , now you can set the OPEN Position Limit.</li> <li>● Click the button UP/DOWN to adjust the open limit position of the door. Click the SET button to confirm the open limit position.</li> </ul>
		<ul style="list-style-type: none"> <li>● Digital now displays automatically , now you can set the CLOSE position limit.</li> <li>● Click the button UP/DOWN, to adjust the close position limit. Click the SET button to confirm.</li> <li>● Then the door drive would automatically open and close the door and save the setting.</li> </ul>
		<p>PS: If there is a faulty , please check if the encoder cable is connected properly. If the connection is normal, please reset the travel limit. When you reset the travel limit, short click the UP /DOWN button and then reset the travel limit.</p>

MENU 1 **1.-** Common Function Setting



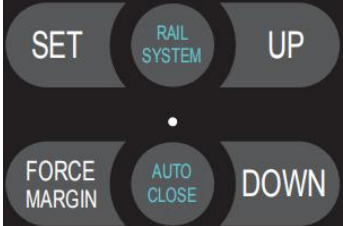





**1.0**  
Wired Push Button Mode Setting











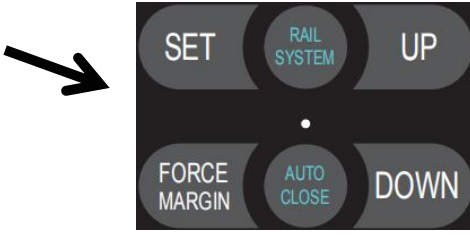



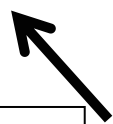







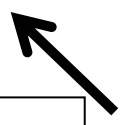













**1.-**  
[Press UP to (1.-)]

**1.0**  
[Press 'SET' to (1.0)]











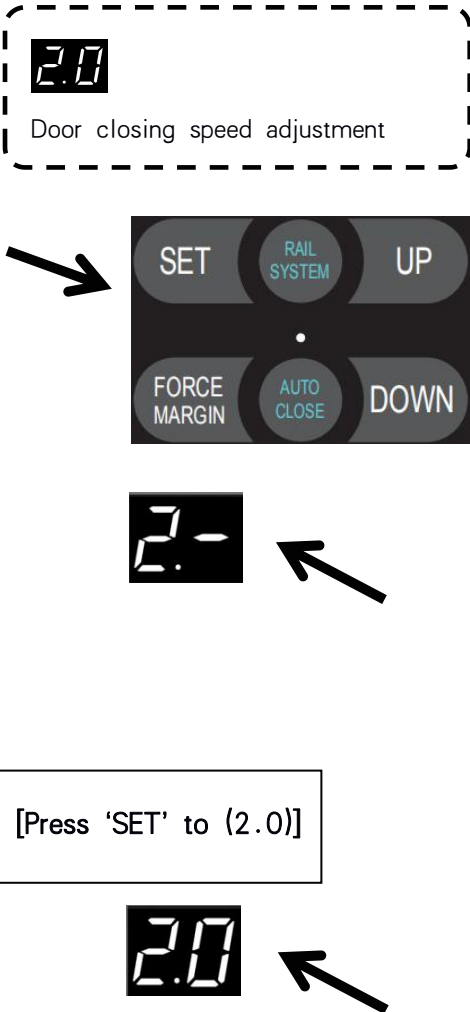

<p><b>1.-</b></p>	<ul style="list-style-type: none"> <li>● Press and hold SET button for about 6 seconds to enter main menu until "0.-" appears on the display then release the button.</li> <li>● Press UP till "1.-" appears on the display, press SET to enter common function setting menu.</li> </ul>
<p><b>1.0</b></p>	<ul style="list-style-type: none"> <li>● After press the SET button on "1.-", "1.0" appears on the display</li> <li>● Press SET to enter the control panel button mode setting.</li> </ul>
<p><b>.1</b></p>	<p><b>.1</b> Execution means:</p> <p>Long press  to open the door ,</p> <p>long press  to close the door</p>
<p><b>.2</b></p>	<p><b>.2</b> Execution means:</p> <p>Click  to open the door ,</p> <p>Long press  to close the door</p>
<p><b>.3</b></p>	<p><b>.3</b> Execution means:</p> <p>Long press  to open the door ,</p> <p>Click  to close the door</p>
<p><b>.4</b></p>	<p><b>.4</b> Execution means:</p> <p>Click  to open the door ,</p> <p>Click  to close the door (default)</p>
<p>Remark:</p>	<ul style="list-style-type: none"> <li>● When the emergency stop function works, Function <b>.1</b> is executed as default button mode.</li> </ul>

		<ul style="list-style-type: none"> <li>● Press and hold SET button for about 6 seconds to enter main menu until “0.—” appears on the display then release the button.</li> <li>● Press UP till “1.—” appears on the display.</li> <li>● Press SET and “1.0” appears on the display,</li> </ul>
 <p>Reversal Distance Ignorance Setting</p>		<ul style="list-style-type: none"> <li>● Press UP till “1.1” appears on the display.</li> <li>● Press SET to enter the Reversal Distance Ignorance Setting</li> </ul>
  <div data-bbox="239 896 566 1008" style="border: 1px solid black; padding: 5px; width: fit-content; margin-left: auto; margin-right: auto;"> <p>[Press UP from (1.0)]</p> </div>		<p>The digital flashes , Adjust the stalls from  to  by button UP or DOWN, Press SET to confirm the function option, automatically exit to the menu  to continue setting the next function menu, or press the RETURN button to exit the function setting.</p>
	<p>Remark:</p>	<p>According to the door rail system and the size of the cable drum, the adjustment range of each setting is between 2–5mm. The customer can choose more appropriate parameters according to the actual state of the door.</p> <p>Default  is about 3.5cm.</p> <p>The calculation format is like this:  <math>[8] * 2 * 2.2\text{mm}</math></p>
 <p>Fine adjustment of the open limit position</p>   <div data-bbox="247 1892 574 2004" style="border: 1px solid black; padding: 5px; width: fit-content; margin-left: auto; margin-right: auto;"> <p>[Press UP from (1.1)]</p> </div>		<ul style="list-style-type: none"> <li>● Press and hold SET button for about 6 seconds to enter main menu until “0.—” appears on the display then release the button.</li> <li>● Press UP till “1.—” appears on the display.</li> <li>● Press SET then “1.0” appears on the display.</li> <li>● Press UP till “1.2” appears on the display,</li> </ul>

		<p>Press SET to enter, digital flashing display ; Use the UP or DOWN buttons to adjust the number displayed on the digital tube between  ...  to . Select the target parameter, press SET to confirm the function option, then exit to the menu , Continue to set the next function menu, or press the cancel button to exit the function setting.</p>
<div data-bbox="240 1173 715 1339" style="border: 1px dashed black; padding: 5px; margin-bottom: 20px;">  Fine adjustment of the close limit position </div>  <div data-bbox="240 1527 568 1639" style="border: 1px solid black; padding: 5px; margin-bottom: 20px;"> [Press UP from (1.2)] </div> 	<p>Remark:</p> 	<p>Default </p> <ol style="list-style-type: none"> <li>Select  to , which means the limit position moves further in the OPEN DOOR direction.</li> <li>Select  to , which means the limit position moves in the door center direction.</li> </ol> <ul style="list-style-type: none"> <li>● Press and hold SET button for about 6 seconds to enter main menu until "0.—" appears on the display then release the button.</li> <li>● Press UP till "1.—" appears on the display.</li> <li>● Press SET then "1.0" appears on the display.</li> <li>● Press UP till "1.3" appears on the display.</li> </ul> <p>Press SET to enter, digital flashing display ; Use the UP/DOWN buttons to adjust the number displayed on the digital display between  ...  to . Select the target parameter, press SET to confirm the function option, then exit to the menu .</p>

	Remark :	Default <b>-5</b> a. Select <b>0</b> to <b>F</b> , which means the limit position moves in the door center direction . b. Select <b>-F</b> to <b>0</b> , which means the limit position moves in the CLOSE DOOR direction .
--	----------	---

<b>MENU2 <b>2.-</b> Operating Parameter Setting</b>		
	<b>2.0</b>	<ul style="list-style-type: none"> <li>● Press and hold SET button for about 6 seconds to enter main menu until "0.-" appears on the display then release the button.</li> <li>● Press UP till "2.-" appears on the display.</li> <li>● Press "SET" into the operating parameter setting menu, digital displays "2.0"</li> <li>● Press SET to enter the door closing speed adjustment menu,</li> </ul>
	<b>.1</b>	High speed, 100% of standard door closing speed
	<b>.2</b>	Medium speed, 90% standard door closing speed
	<b>.3</b>	Low speed, 80% standard door closing speed
	<b>.4</b>	Low speed, 70% standard door closing speed
Remark :		After quick setting the door drive,AAS function automatically select the most optimized speed for the door already . When you change the speed manually in this menu,you have to set the travel position limit again to ensure door drive works properly .
	<b>2.1</b>	<ul style="list-style-type: none"> <li>● Press and hold SET button for about 6 seconds to enter main menu until</li> </ul>

<div style="border: 1px dashed black; padding: 5px; margin-bottom: 20px;">  <p>Door opening speed adjustment</p> </div> 		<p>“0.—” appears on the display then release the button.</p> <ul style="list-style-type: none"> <li>● Press UP till “2.—” appears on the display.</li> <li>● Press “ SET ” into the operating parameter setting menu, digital displays “2.0”</li> <li>● Press UP till “2.1” appears on the display</li> <li>● Press SET to enter the door opening speed adjustment menu,</li> </ul>
	<p>High speed, 100% of standard door opening speed</p>	
	<p>High speed, 90% of standard door opening speed</p>	
	<p>Medium speed, 80% of standard door opening speed</p>	
	<p>Low speed, 70% of standard door opening speed</p>	
<p>Remark:</p>	<p>After quick setting the door drive,AAS function automatically select the most optimized speed for the door already. When you change the speed manually in this menu,you have to set the travel position limit again to ensure door drive works properly.</p>	
<div style="border: 1px dashed black; padding: 5px; margin-bottom: 20px;">  <p>Soft closing distance adjustment</p> </div> 		<ul style="list-style-type: none"> <li>● Press and hold SET button for about 6 seconds to enter main menu until “0.—” appears on the display then release the button.</li> <li>● Press UP till “2.—” appears on the display.</li> <li>● Press “ SET ” into the operating parameter setting menu, digital displays “2.0”</li> <li>● Press UP till “2.2” appears on the display</li> <li>● Press SET to enter the Soft closing distance adjustment,</li> </ul>
	<p>Soft closing distance SL:10CM, HL:20CM, VL: 25CM</p>	



		Soft closing distance SL:20CM, HL:30CM, VL: 40CM
		Soft closing distance SL:25CM, HL:45CM, VL: 50CM
		Soft closing distance SL:40CM, HL:55CM, VL: 60CM
	Remark:	The above soft closing distance is estimated with 18-inch cable drum. The actual distance will be different according to the customer's cable drum diameter. The rail system (AAS) will automatically match the optimized soft closing distance. After the customer changes the default distance, the previous travel limit will be lost and needs to be re-learned.

**MENU3 Soft Stop (during-operation) Function Setting**

Soft stop (during-operation) function adjustment

- Press and hold SET button for about 6 seconds to enter main menu until "0.-" appears on the display then release the button.
- Press UP till "3.-" appears on the display.
- Press SET into the Soft stop (during-operation) function adjustment

The digital tube display , Number 1 flashing display (default).

Adjust the stalls from to by buttons UP/DOWN. This function is used to control the soft stop and corresponding soft stop speed during operation. Press the SET button to confirm the selection and automatically exit the function menu.

	Remark:	<p>The soft stop function is enabled by default <b>3.1</b>, Whether it is an external device or a remote control, the soft stop function is implemented during operation.</p> <p><b>3.0</b> means: Soft stop function is off</p> <p>3.1 means soft-stop will low-down the speed to 30% in 0.75 second, then stop the door</p> <p>3.2 means oft-stop will low-down the speed to 40% in 0.75 second, then stop the door.</p> <p>3.3 means oft-stop will low-down the speed to 50% in 0.75 second, then stop the door.</p> <p>3.4 means oft-stop will low-down the speed to 60% in 0.75 second, then stop the door.</p>
--	---------	--

**MENU4 **4.-** AUTO CLOSE Time & Condition Setting**

**4.-**  
AUTO CLOSE time setting

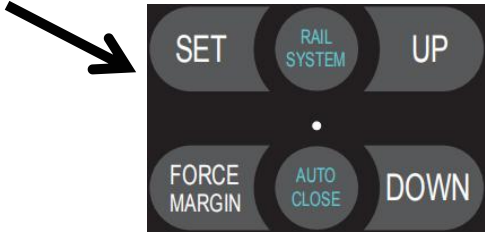

4.0

4.-

- Press and hold SET button for about 6 seconds to enter main menu until "0.-" appears on the display then release the button.
- Press UP till "4.-" appears on the display.
- Press SET enter into the AUTO CLOSE time and condition setting
- Press SET again to enter, the digital displays **03** (default)

Adjust the stalls from **01** to **99** by buttons UP/DOWN, 5 seconds per stall  
 AUTO CLOSE time calculation method is 5S\*N, N=01—99.

The maximum AUTO CLOSE time is 495S, press the SET button to store the required AUTO CLOSE time setting, then the digital tube displays **4.1** (default) which means that it has entered the AUTO

	<p>CLOSE condition setting, Adjust by buttons UP/DOWN from <b>41</b> or <b>42</b> or <b>43</b>.</p> <p>Select the corresponding function, press the SET button to save and exit the menu setting.</p>
Remark:	The AUTO CLOSE function is turned on, which means the door is controlled by the AUTO CLOSE button on the control box.
<b>41</b>	Condition <b>41</b> means: Only after the door is opened to the open limit position, the AUTO CLOSE function is effective and starts timing.
<b>42</b>	Condition <b>42</b> means: After the door stops at any position when opening, the AUTO CLOSE function is effective and starts timing.
<b>43</b>	Condition <b>43</b> means: No matter where the door is open, as long as it is not at the close limit position, it will automatically close.
Remark:	<p>a. If the infrared function is turned on, the AUTO CLOSE timing will stop when the infrared is blocked by an obstacle. After the obstacle removed, it will continue the previous timing and automatically close the door.</p> <p>b. When the door is about to close, the courtesy light flashes for warning.</p> <p>c. When the door is about to close, the warning light flashes to warn.</p> <p>d. Note: The flashing time of the warning light follows the courtesy light.</p> <p>e. The AUTO CLOSE function can only be used when the safety protection device is used correctly</p>

**MENU5** **5.-** Infrared Beam & Light Curtain Function

**5.-**  
Infrared function off and on

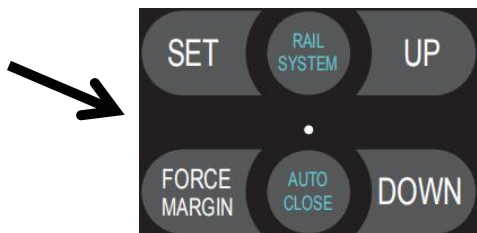

**5.0**

**0**

**4**

**5.-**

**5.0**

**0**

**4**

- Press and hold SET button for about 6 seconds to enter main menu until "0.-" appears on the display then release the button.
- Press UP till "5.-" appears on the display.
- Press SET into the Infrared Beam & Light Curtain function
- Press SET to enter, the digital displays **5.0** (default) ;
- Adjust the stalls from **5.0** to **5.1** by buttons UP/DOWN.  
**5.0** means: The infrared interface function is closed.  
**5.1** mean: The infrared function interface is enabled.
- Select **5.0** function (default) , Press SET to save and exit the function menu.
- Select **5.1** function, which means the infrared function is enabled. Then after pressing the SET button to save setting, the digital displays **0** immediately after this operation, means entering the coordination setting of infrared function and Auto-close function. Adjust the stalls from **0** to **4** by buttons UP/DOWN.  
**0** means: The infrared function is not related to the AUTO CLOSE function.

	<p><b>4</b> means: The AUTO CLOSE function must be enabled after the infrared function is turned on.</p> <p>After selecting, press SET to save the setting and exit the function setting.</p>
	<p>Remark: Use the Normal–Close (NC) port of the infrared photoelectric device to connect to the PE port of the control box. The infrared PE port defaults to a Normal–Close (NC) contact to ensure that the infrared photoelectric device has been installed correctly. If the infrared photoelectric device is not installed, this function must be disabled, otherwise the drive unit cannot execute close the door.</p> <p>And digital displays faulty <b>EE</b>.</p>

**MENU6 **6.-** Terminals for Extra Function Setting**

**6.0**  
Partial open position setting

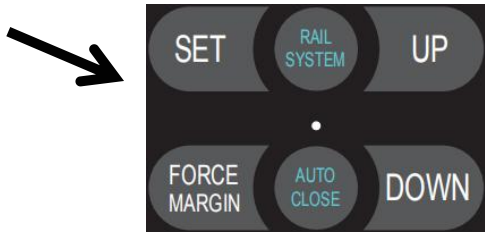







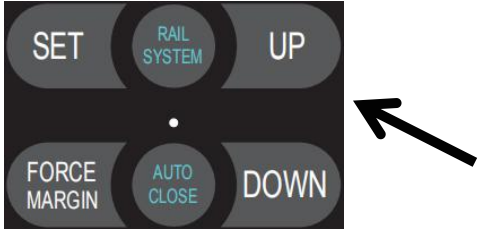

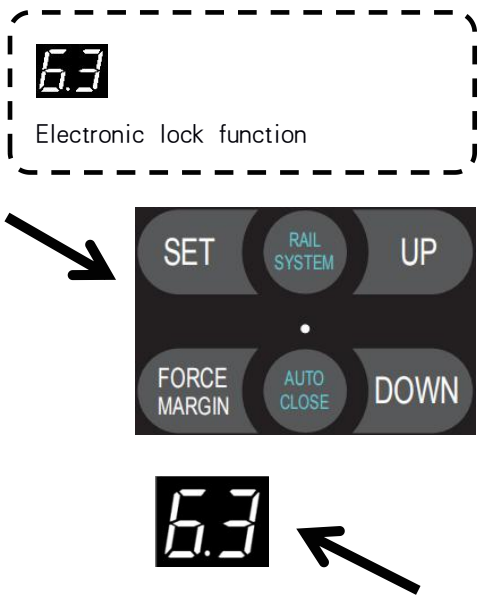



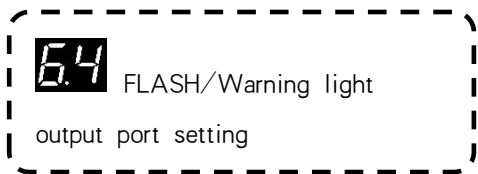

**6.0** ←

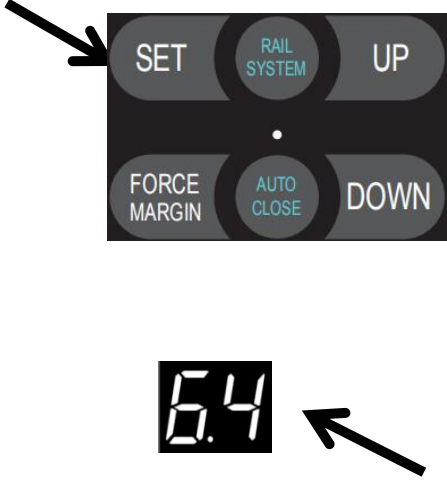

**1-1** ←

- Press and hold SET button for about 6 seconds to enter main menu until “0.-” appears on the display then release the button.
- Press UP till “6.-” appears on the display.
- Press SET then appears “6.0” on the display
- Press SET enter into the Partial open position setting
- Press SET to enter the function menu, digital quickly display **1-1**, Then it flashes **5**,
- Adjust the stalls from **.1** to **.9** by buttons +/- . (9 stalls represent 10%–90% of the door travel)

		<p>limit)</p> <ul style="list-style-type: none"> <li>● Press SET to confirm and exit to the menu <b>10</b>.</li> </ul> <p>You can continue to set the next function menu. Or press the RETURN button to exit the function setting.</p>
	Remark :	<p><b>5</b> (default).</p> <p>It means that the partial open door position is 50% of the full travel limit.</p>
<div style="border: 1px dashed black; padding: 5px; margin-bottom: 10px;"> <p><b>6.2</b></p> <p>PB Port function setting (NO)</p> </div>  <p><b>6.2</b></p>	<b>6.2</b>	<ul style="list-style-type: none"> <li>● Press and hold SET button for about 6 seconds to enter main menu until "0.-" appears on the display then release the button.</li> <li>● Press UP till "6.-" appears on the display.</li> <li>● Press SET then appears "6.0" on the display</li> <li>● Press UP till "6.2" appears on the display.</li> <li>● Press SET enter into the PB Port function setting.</li> </ul>
	<b>.1</b>	<p><b>.1</b> Execute OPEN-STOP-CLOSE the door...Single-cycle function</p>
	<b>.2</b>	<p><b>.2</b></p> <ul style="list-style-type: none"> <li>● Execute CLOSE the door at the open limit position</li> <li>● OPEN the door at the close limit position</li> <li>● ONLY OPEN the door in the middle of the travel limit</li> </ul>
	<b>.3</b>	<p><b>.3</b> Execute ONLY OPEN the door (Specified application scenarios, Fire alarm, infrared sensor to open the door)</p>
	<b>.4</b>	<p><b>.4</b> Execute PARTIAL OPEN the door</p>
	<b>.5</b>	<p><b>.5</b> Execute REVERSE during door closing (default)</p>

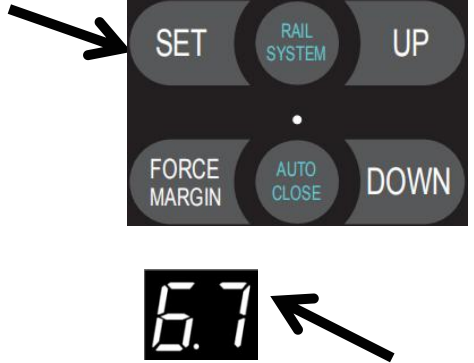

	Remark :	 Execute REVERSE during door closing (default)
		<ul style="list-style-type: none"> <li>● Press and hold SET button for about 6 seconds to enter main menu until "0.—" appears on the display then release the button.</li> <li>● Press UP till "6.—" appears on the display.</li> <li>● Press SET then appears "6.0" on the display</li> <li>● Press UP till "6.3" appears on the display.</li> <li>● Press SET enter into the Electronic lock function setting.</li> </ul>
	Remark :	 Electronic lock function is off (default)
		 <p>Electronic lock function is enabled:  1 second after the door drive runs to the close limit position, the electronic lock is powered on, the bolt is pushed out, and after 1.5 seconds electronic lock stops supplying power.  After the door drive receives the door opening command at the close limit position, the electronic lock will be powered on firstly to retract the bolt, then the door starts to run after 1.5 seconds, and the electronic lock stops power supply after the door runs for 1 second.</p>
	Remark :	The default electronic lock function is off.
		<ul style="list-style-type: none"> <li>● Press and hold SET button for about 6 seconds to enter main menu until "0.—" appears on the display then release the button.</li> <li>● Press UP till "6.—" appears on the display.</li> <li>● Press SET then appears "6.0" on the display</li> </ul>







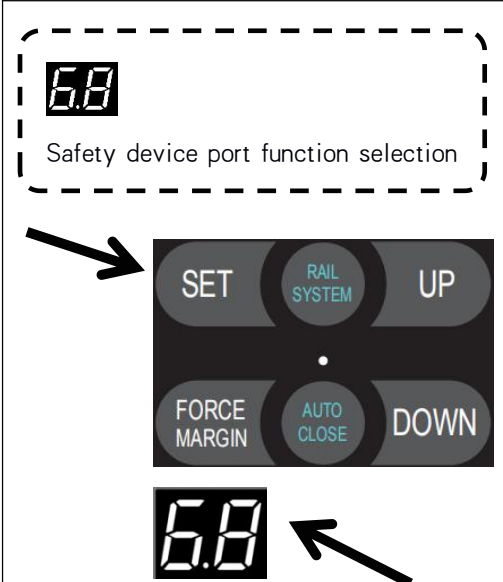

		<ul style="list-style-type: none"> <li>● Press UP till “6.4” appears on the display.</li> <li>● Press SET enter into the FLASH/Warning light output port setting.</li> </ul>
		Warning light flashes when the door is running, and warning light off when the door is stop. (default)
		The warning light is always on when the door is running, and the warning light is off when the door is stop.
		The warning light flashes when the door is running, and the warning light flashes also when the door is stop.
		The warning light is always on when the door is running, and the warning light is always on also when the door is stop.
		The warning light flashes when the door is running, and the warning light is always on when the door is stop.
		The warning light is always on when the door is running, and the warning light flashes also when the door is stop.
	Remark :	 means: Warning light flashes when the door is running, and warning light off when the door is stop. (default)

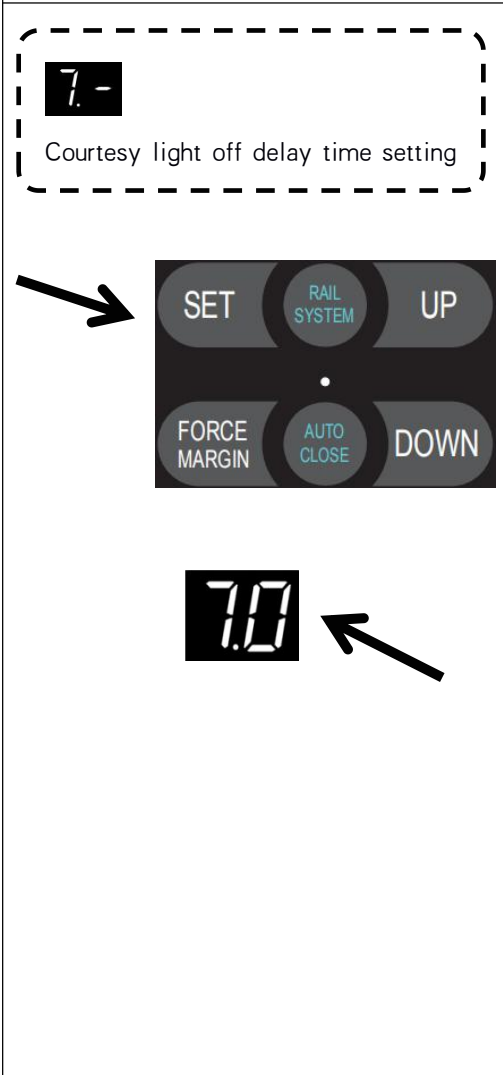
<div data-bbox="240 1451 715 1626" style="border: 1px dashed black; padding: 5px;">  XH06 Relay output module function setting </div> 		<ul style="list-style-type: none"> <li>● Press and hold SET button for about 6 seconds to enter main menu until “0.—” appears on the display then release the button.</li> <li>● Press UP till “6.—” appears on the display.</li> <li>● Press SET then appears “6.0” on the display</li> <li>● Press UP till “6.7” appears on the display.</li> <li>● Press SET enter into XH06 Relay output module function setting. (Refer to page 33 – Relay module output terminal)</li> </ul>
		Reach the open limit position, relay closed



		Reach the close limit position , relay closed
		Reach the partial open limit position, relay closed
		<p>Before the door drive running, the relay is closed first (1–7 seconds time adjustable) Press SET to confirm and directly enter the time setting. Adjust the stalls from  to  by buttons UP/DOWN.</p> <p> default: Represents 3 seconds.</p>
		<p>Relay always closed during the door drive running. After the door drive stops, relay will be disconnected after 1–10 minutes delay.(Adjustable time, similar to courtesy light OFF DELAY function).</p> <p>Press SET to confirm and directly enter the time setting. Adjust the stalls from  to  by buttons UP/DOWN.A=10.</p> <p> means : 10 minutes ;  default: Represents 3 minutes</p>
		The relay is closed during door drive operation.
		When the door drive running, the relay flashes at a frequency of 1HZ (externally extended warning light function)
		Relay no action
	Remark :	<p> default.</p> <p>The customer can set the function according to the specific application and choose the appropriate function with the Normal–Open (NO) and Normal–Close (NC) function of the relay.</p>
		<ul style="list-style-type: none"> <li>● Press and hold SET button for about 6 seconds to enter main menu until “0.—” appears on the display then release the button.</li> </ul>

	<ul style="list-style-type: none"> <li>● Press UP till “6.—” appears on the display .</li> <li>● Press SET then appears “6.0” on the display</li> <li>● Press UP till “6.8” appears on the display .</li> <li>● Press SET enter into Safety device port function selection</li> </ul>
	<p>Use optical edge sensor kit. Or 8.2K resistor in series with the rope switch.</p>
	<p>Use three-wire infrared photo eyes.</p>
<p>Remark :</p>	<p>8.2K resistor is used to short-circuit the safety port by default.</p>

<b>MENU7  Courtesy Light Function Setting</b>	
	 <ul style="list-style-type: none"> <li>● Press and hold SET button for about 6 seconds to enter main menu until “0.—” appears on the display then release the button.</li> <li>● Press UP till “7.—” appears on the display .</li> <li>● Press SET into Courtesy light off delay time setting.</li> <li>● Press SET to enter the function menu, digital tube display .</li> <li>● Adjust the stalls from  to  by buttons UP/DOWN.  default, means 3 minutes delay. 1 minute per stall. It is adjustable for 1—9 minutes. Select the delay time of the courtesy light, press the SET button to save setting, At the same time, enter the warning function setting of the courtesy light, digital tube display , Adjust the stalls from  to  by buttons UP/DOWN.</li> </ul>

	<p><b>0</b> means the courtesy light operation warning function is off.</p> <p><b>0</b> to <b>.9</b> means: The corresponding warning 1–9 second time selection, 1–9 second option means flashing before door drive starts running.</p>
Remark:	<p>a. After the door drive stops running, the courtesy light delay time can be adjusted from 1 ~ 9 minutes, the default is <b>73</b>, means 3 minutes off delay.</p> <p>b. After the courtesy light warning function is turned on, the courtesy light will flash for a corresponding time before the door drive runs each time, and then the door drive will start to perform actions.</p>

**MENU8 **8.-** Maintenance Alarm Function Setting**

**8.0** Maintenance alarm cycle-counting setting

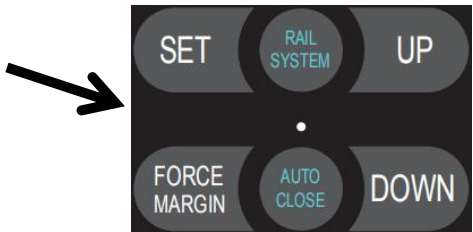

**8.0** ←

**8.0**









- Press and hold SET button for about 6 seconds to enter main menu until “0.-” appears on the display then release the button.
- Press UP till “8.-” appears on the display. Press SET then “8.0” appears on the display.
- Press SET to enter the Maintenance alarm cycle-counting setting.

---





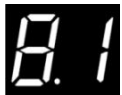



**0** Indicates that the maintenance alarm function is closed (factory default)

Press SET to enter the function menu, digital displays **0** (factory default).

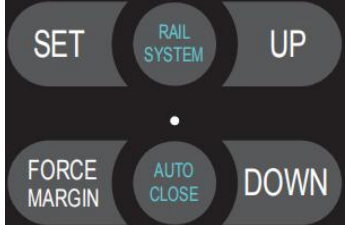







Adjust the stalls from **.1** to





		<p> then  by buttons UP/DOWN. 500 cycles per stall. Cycles—calculation method is <math>500 \times N</math>, <math>N=01—15</math>. A=10; F=15 e.g.  means: <math>1 \times 500 = 500</math> cycles;  means: <math>2 \times 500 = 1000</math> cycles;  means: <math>10 \times 500 = 5000</math> cycles;  means: <math>15 \times 500 = 7500</math> cycles</p>
<p> Query the remaining cycles of maintenance alarm</p> <p> ←</p>	<p></p>	<ul style="list-style-type: none"> <li>● Press and hold SET button for about 6 seconds to enter main menu until “0.—” appears on the display then release the button.</li> <li>● Press UP till “8.—” appears on the display. Press SET then “8.0” appears on the display.</li> <li>● Press UP till “8.1” appears on the display, Press SET to enter the Query the remaining cycles of maintenance alarm</li> </ul>
		<p>Press SET to enter the function query, the digital will circulated display , then after the cumulative loop display 3 times, the query display will exit.</p>
	<p>Remark:</p>	<ol style="list-style-type: none"> <li>Running cycles counter will not be cleared even after the door drive is restored to factory settings.</li> <li>Maintenance alarm description (Running cycles will minus 1 cycle, after the door drive reaching the close limit position each time)</li> <li>When the maintenance alarm count shows 0, when the door drive runs to the open and close limit positions each time, the courtesy</li> </ol>

		<p>light will flash quickly, the buzzer will sound continuously to remind the customer that the door and the drive unit need maintenance, and the digital tube will display fault <b>EB</b>.</p> <p>d. After the maintenance of the door or drive unit is completed, the maintenance personnel need to re-enter the menu to set the maintenance alarm cycles, and the cycles of maintenance alarms will restart to count.</p>
--	--	---

<b>MENU9  Gear Motor Running Direction Rotating Setting</b>		
<div data-bbox="240 1003 715 1173" style="border: 1px dashed black; padding: 5px;">  Door drive output rotating direction setting         </div> <div data-bbox="240 1205 715 1429" style="text-align: center;">  </div> <div data-bbox="427 1485 687 1592" style="text-align: center;">  ←         </div>		<ul style="list-style-type: none"> <li>● Press and hold SET button for about 6 seconds to enter main menu until "0.-" appears on the display then release the button.</li> <li>● Press UP till "9.-" appears on the display.</li> <li>● Press SET to enter the Door drive output rotating direction setting</li> </ul>
		 Door drive rotating direction is forward. (Default)
		 Door drive rotating direction is reverse
Remark :		After adjusting the rotating direction of the door drive, it is necessary to relearn the travel limit.

## FAULT DISPLAY

Fault Display Code	Fault Description	Fault Correction
	Encoder failure, the encoder cannot write and read data	<ol style="list-style-type: none"> <li>1. Replace the encoder</li> <li>2. Replace the encoder cable</li> </ol>
	No motor motion signal is detected,	<ol style="list-style-type: none"> <li>1. Check whether the wiring between the limiter and the control board is loose.</li> </ol>
	The positive and negative poles of the motor wire are reversed	<ol style="list-style-type: none"> <li>1. Exchange the positive and negative poles of the motor</li> </ol>
	Motor current is too high	<ol style="list-style-type: none"> <li>1. Choose matching control system and motor</li> <li>2. Check the door body</li> <li>3. Replace the high-power door drive</li> </ol>
	Door drive overload alarm, current overrun	<ol style="list-style-type: none"> <li>1. The door is stuck or the door is too heavy</li> <li>2. The door size is too large</li> <li>3. Check the door body</li> <li>4. Replace the high-power door drive</li> </ol>
	Optical safety edge sensor kit fault	<ol style="list-style-type: none"> <li>1. 8.2K resistor is open circuit, missing installation</li> <li>2. The conductive tape edge is aging or broken</li> </ol>
	Infrared/infrared light curtain function port is triggered	<ol style="list-style-type: none"> <li>1. Check whether the infrared function is turned on</li> <li>2. Turn on the infrared function to detect whether the infrared device is blocked</li> <li>3. Check whether the NO/NC wiring of the infrared device output port is wrong. The NO port is connected by default, and the port is closed after the shot</li> </ol>
	SD (Pass door/wicket door) switch is triggered	<ol style="list-style-type: none"> <li>1. Check whether the SD function port of the secure port is not connected</li> </ol>
	The maintenance alarm cycle reaches	<ol style="list-style-type: none"> <li>1. Notify maintenance personnel to maintain the door and drive</li> </ol>

	<p>Safety port three-wire infrared fault</p>	<ol style="list-style-type: none"> <li>1. The three-wire infrared electric photo eye is blocked</li> <li>2. Three-wire infrared electric photo eye failure</li> <li>3. Is the three-wire infrared electric photo eye a product of our company?</li> </ol>
	<p>Communication failure between door drive and control panel.</p>	<ol style="list-style-type: none"> <li>1. Re-plug the 8P ribbon cable</li> <li>2. The door drive needs to be powered off and restarted</li> <li>3. Replace the 8P ribbon cable</li> </ol>
	<p>Short learning travel limit</p>	<ol style="list-style-type: none"> <li>1. Re-learn the travel limit</li> <li>2. Encoder position data failure</li> </ol>
	<p>During the self-learning of the travel limit, if the rotor is blocked or the encoder is faulty, the buzzer will sound once and display "EE."</p>	<ol style="list-style-type: none"> <li>1. Re-learn the limit position.</li> <li>2. Check the encoder connection</li> <li>3. Replace the encoder</li> </ol>
	<p>The emergency stop switch function is triggered.</p>	<ol style="list-style-type: none"> <li>1. Check whether the emergency stop switch is pressed</li> <li>2. Whether the emergency stop switch uses a normally closed (NC) switch</li> <li>3. Whether the external port STOP short-circuit connection is loose</li> </ol>

## TX/RX FUNCTION MODULE DESCRIPTION (optional)

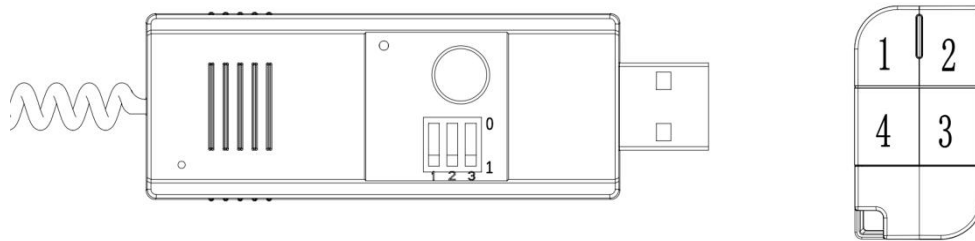

1. The external decoding module uses the standard HCS301 format open code, the frequency 433MHZ/868MHZ is optional,
2. Transmitter 4 button design; Transmitter key value 1, 8, 2, 4
3. The transmitter module and control box use USB standard interface to connect
4. Short press the LEARN button on the module, the LED will light up, press the remote control to learn the code. Long press the learn button on the module for 6 seconds, LED will flash 5secondsquickly to clear the code
5. The default maximum number of transmitter storage is 50codes, and if 50 codes is already learned, the 51<sup>st</sup>codewill automatically cover the 1<sup>st</sup>code.
6. **Transmitter module function:**
  - a. Standard function: Single key cycle
  - b. Ignore the key value function, all keys are valid: OPEN—STOP—CLOSE command order each cycle. As long as learning a key, the others are valid
  - c. Multiple function key 1:
    - 1<sup>st</sup> button execute OPEN—STOP—CLOSE command order each cycle ;
    - 2<sup>nd</sup> button execute PARTIAL OPEN command order;
    - 3<sup>rd</sup> button execute courtesy light ON/OFF command order;
    - 4<sup>th</sup> button execute remote LOCK command order;
  - d. Multiple function key 2:
    - 1<sup>st</sup> button execute OPEN the door command order;
    - 2<sup>nd</sup> button execute STOP command order;
    - 3<sup>rd</sup> button execute CLOSE the door command order;
    - 4<sup>th</sup> button execute remote LOCK command order;
  - e. Multiple function key 3:
    - 1<sup>st</sup> button execute OPEN the door command order;
    - 2<sup>nd</sup> button execute STOP command order;
    - 3<sup>rd</sup> button execute CLOSE the door command order;
    - 4<sup>th</sup> button execute “CF” command order; (“CF”command order means press the 4<sup>th</sup> button, the door will OPEN directly without STOP action, execute the REVERSE action during door closing)
7. Adjust the transmitter function through the three—circuit DIP switch

### Important Note:

When using multiple function keys, you must use our company's standard transmitter. The transmitter provided by the customer has inconsistent key values, which may cause function failure.



S1	S2	S3	Function Description
1	1	1	Standard function (Factory default)
0	1	1	Ignore the key value function
1	0	1	Multiple function key 1
1	1	0	Multiple function key 2
0	0	1	Multiple function key 3

## FUNCTION WIRING DIAGRAM

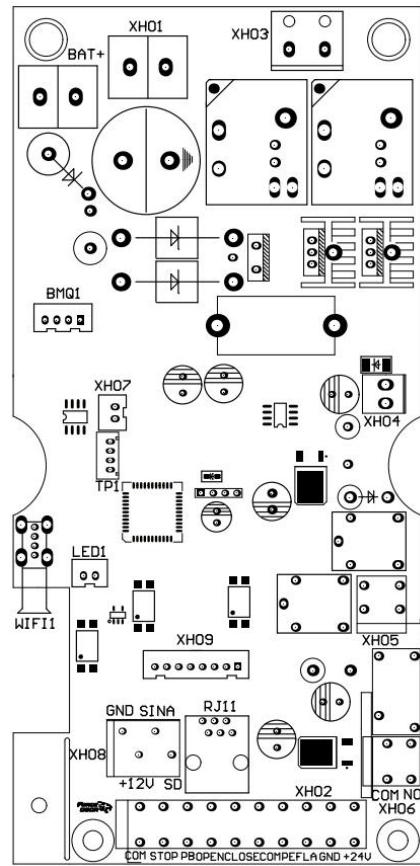

XH01	DC24V Power input terminal
XH02	External function terminal
XH03	Gear motor power supply terminal
XH04	DC24V Input terminal
XH05	Electronic lock terminal
XH06	Relay module output terminal
BAT+	Lead-acid battery input terminal
RJ11	Wall switch terminal
WIFI1	WIFI control terminal
LED1	Courtesy light terminal
XH08	Safety terminal
XH09	Display board terminal

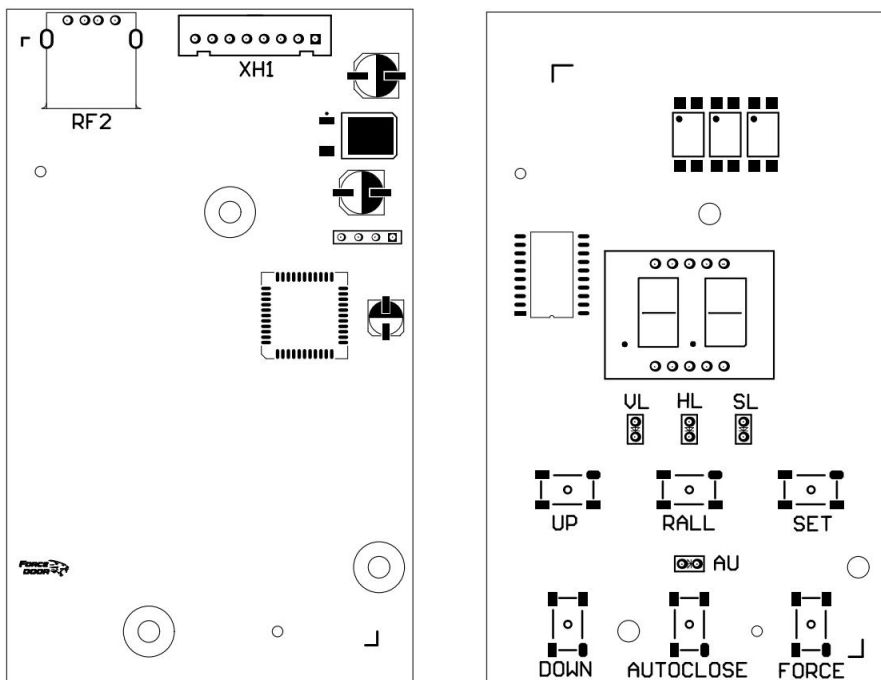

XH1	Display board terminal
RF2	Transmitter receiver module terminal

## XH02 Door drive output terminal

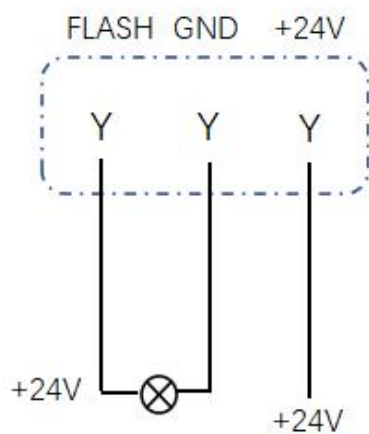

FLASH/GND	DC24V warning light output terminal, drive MAX current 0.2A, function menu <b>64</b> , define function status
+24V/GND	DC 24V/ MAX 0.2A

## XH05 Electronic lock output terminal

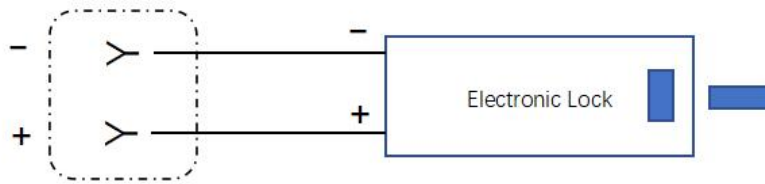

+/-	±24V Electronic lock output terminal, output current max. 2A, time 3S, function menu <b>5.3</b> enabled
-----	--

## XH06 Relay module output terminal

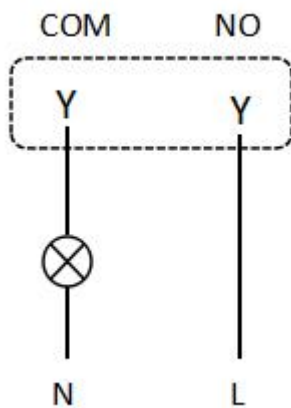

COM/NO	XH06 Relay output module, max 100w. See the function menu <b>5.7</b> for details
--------	---

## XH08 Safety terminal

(optical safety edge/wicket door protection)

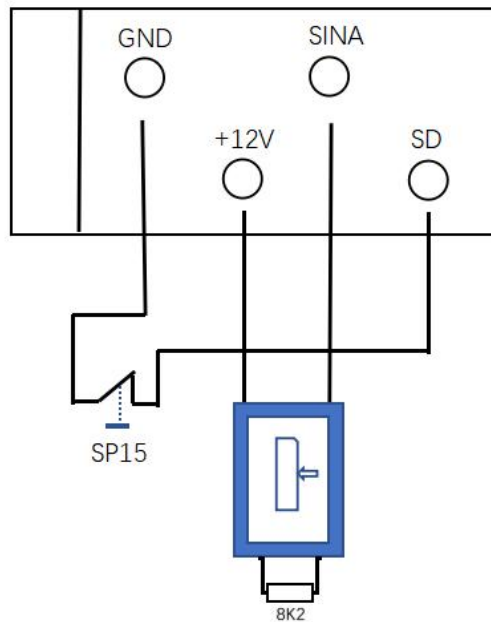



GND	GND
+12V	+12V
SINA	Signal
SP15/SD	Safety contact ,wicket door slackline protection
<p>Note: SP15 is disconnected, the door drive stops, and all control functions are invalid. The optical safety edge is short-circuited during the closing process, and the door drive automatic reverse.</p>	

## XH08 Safety terminal

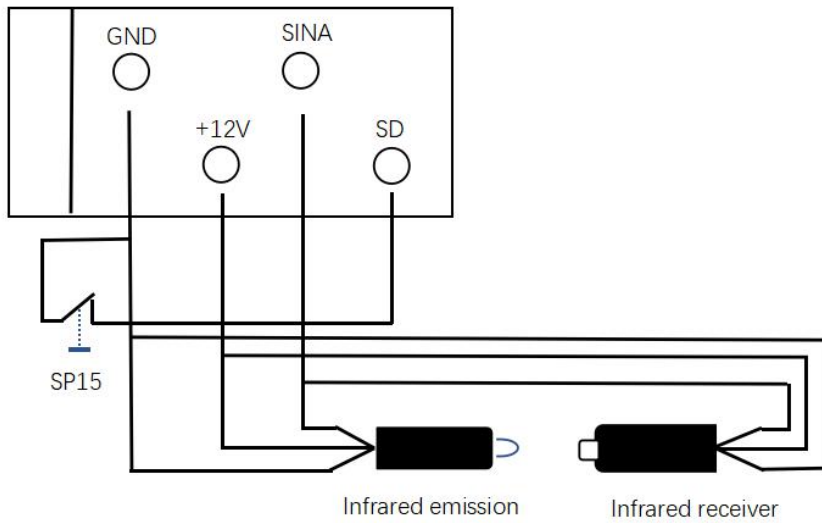
(three-wire infrared sensors/wicket door protection)





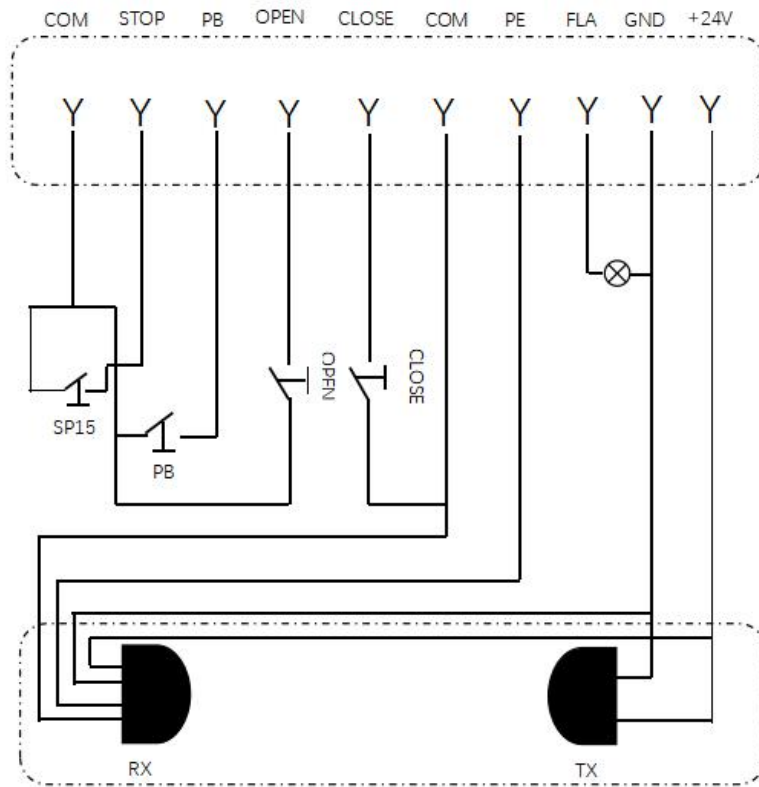

GND	GND
+12V	+12V
SINA	Signal
Three-line infrared	Enable function menu  /  Enable three-wire infrared sensor port sensors (use our standard infrared sensors)
SP15/SD	Safety contact, wicket door slackline protection
Note: SP15 is disconnected, the motor stops, and all control functions are invalid. In the closing process, the three-wire infrared sensors are blocked during the closing process, and the door drive automatic reverse.	

## XH02 Safety terminal

(four-wire infrared sensors/infrared light curtain)



STOP	Emergency stop normally open (NO) port, after connection, the door drive executes long press operation mode
PB	Door drive operation control terminal, see details for specific functions  Function menu normally open (NO) port
OPEN	External door opening terminal normally open (NO) port The external switch can be defined the  function for button mode.
CLOSE	External door closing terminal normally open (NO) port The external switch can be defined the  function for button mode.
PE	Infrared sensors, infrared light curtain, see details  Function enable menu
+24V/GND	DC24V Output power, max 0.2A

Date Version: 17/06/2021

## Declaration of Incorporation

pursuant to Machinery Directive 2006/42/EC for a partly completed machine Appendix II Part B

## Declaration of conformity

in terms of EMC Directive 2014/30/EU

We, the  
**Wuxi Force Technology Co., Ltd**  
**Address: Building H, Plainvim International Industrial Park, Wanquan Road, Wuxi,  
214000 Jiangsu, China**

hereby declare that the following products are conform with the above EC Guideline and are only intended for installation in door equipment.

### **BASE 35, BASE 50, BASE 70**

Standards applied

#### **EN 12453 article 5.3.2**

Industrial, commercial and garage doors and gates - Safety in use of power operated doors -Requirements

#### **EN 60335-1**

Household and similar electrical appliances - Safety - Part 1: General requirements

#### **EN 60335-2-103**

Household and similar electrical appliance - Safety- Part 2 -103 : particular requirements for drives for gates, doors and windows.

#### **EN 61000-6-3**

Electromagnetic compatibility (EMC) Part 6-3 Generic standards – Emission standard for residential, commercial and light-industrial environments

#### **EN 61000-6-2**

Electromagnetic compatibility (EMC) Part 6-2 Generic standards – Immunity standard for industrial environments

Incomplete machines within the meaning of the EC Directive 2006/42/EC shall only be intended to be integrated into other machines (or into other incomplete machines/systems) or to be assembled with them to form a complete machine within the sense of the Directive. Therefore, this product cannot be commissioned before it is determined that the entire machine/system to which it was integrated shall comply with the provisions of the Machinery Directive indicated above.

**Date: 17-06-2021**

**Jevons Liang**

General Manager



Signature