

BASE 70

Industrial Door Drive

Operator

Mechanical Installation And User Guide

CONTENTS

| | |
|--|-----|
| 1. GENERAL SAFETY INFORMATION..... | 1 |
| 2. TECHNICAL DATA..... | 2 |
| 3. DIMENSION..... | 3 |
| 4. PREPARATION..... | 4 |
| 5. MECHANICAL INSTALLATION..... | 5-7 |
| 6. EMERGENCY MANUAL OPERATION (Rapid hand chain operator)..... | 8-9 |
| 7. COMPLETING COMMISSIONING / INSPECTION..... | 10 |

Symbols



Warning - Potential injury or danger to



Warning - Danger to life from electric



Note - Important



Requirement - Required action!

* Schematic representations are based on product examples. Deviations from delivered products are possible.

1. GENERAL SAFETY INFORMATION

Specified use

The industrial door drives intended for a power-operated door with a control unit.

The safe operation is only guaranteed with specified normal use. The drive unit is to be protected from rain, moisture and aggressive ambient conditions. No liability for damage caused by other applications or non-observance of the information in the manual.

Modifications are only permitted with the agreement of the manufacturer. Otherwise the Manufacturer's Declaration shall be rendered null and void.

Safety information

Installation and commissioning are to be performed by skilled personnel only.

Only trained electrical craftsmen are permitted to work on electrical equipment. They must assess the tasks assigned to them, recognize potential danger zones and be able to take appropriate safety measures.

Installation work is only to be carried out with the supply off.

Observe the applicable regulations and standards.

Coverings and protective devices

Only operate with corresponding coverings and protective devices.

Ensure that gaskets are fitted correctly and that cable glands are correctly tightened.

Spare parts

Only use original spare parts.

2. TECHNICAL DATA

| | |
|--|---------------------------|
| Model | BASE 70 |
| Max. output torque (Nm) | 70 |
| Rated output torque (Nm) | 50 |
| Output speed (rpm) | 24-32 |
| Output shaft/hollow shaft (mm) | φ25.4 |
| Static holding torque (Nm) | 400 |
| Door area (m ²) | ≤28 |
| Input voltage (V) | 110-127/220-240 & 380-420 |
| Motor power (W) | 550 |
| Control system | 24V DC |
| Thermal protection temperature (°C) | 105 |
| Max. cycles per hour (Cycle) | 20 |
| Class of protection | IP 54 |
| Limit switch range (maximum revolutions of output shaft / hollow shaft) | 15 |
| Temperature range (°C) | -20 ~ +40 (+60) |

* When using a temperature range of +40°...+60°C use half of maximum cycles per hour.

3. DIMENSION

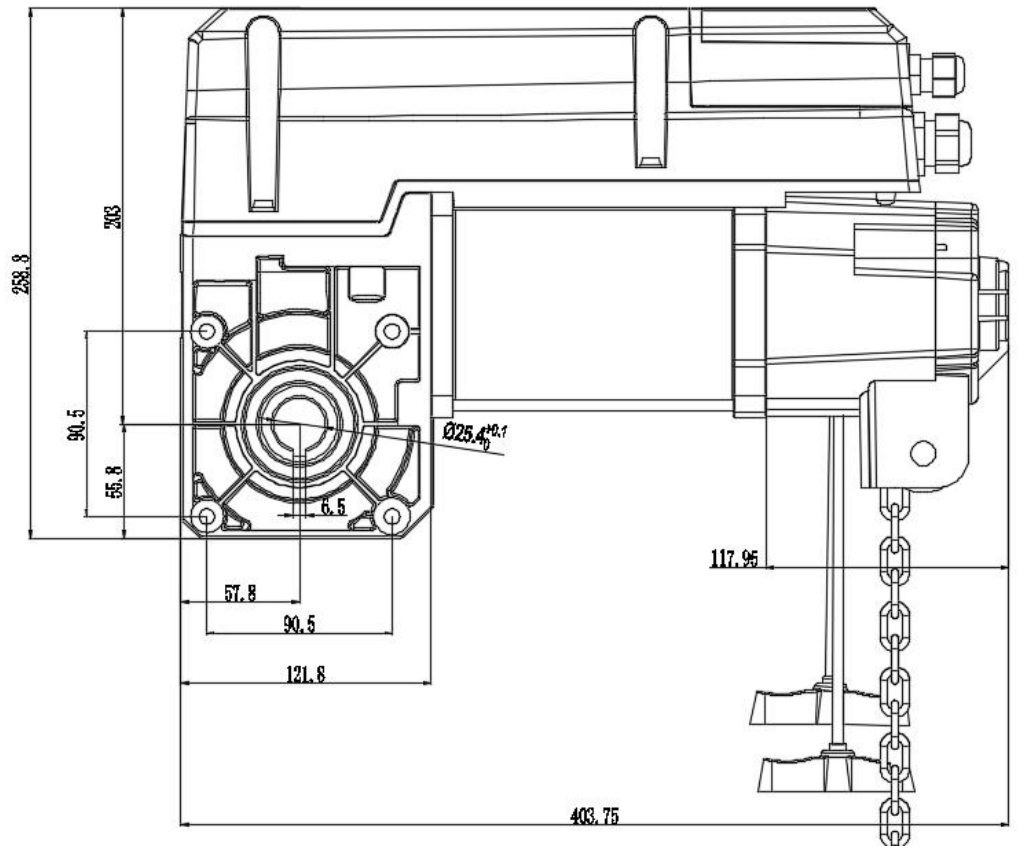
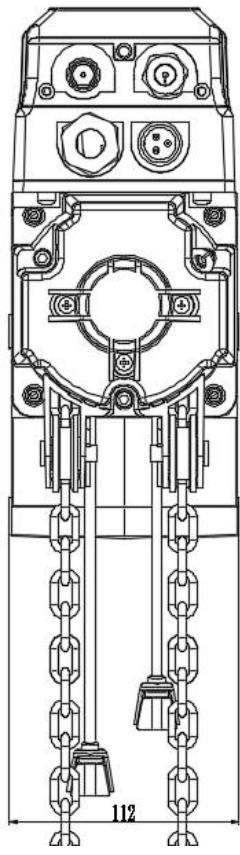

4. PREPARATION

Danger!

To avoid injury, the following points must be observed:

- The operator must be installed free of any tension.
- The operator must not move on the shaft.
- The design and subsurface of all components must be suitable for the forces encountered.

Warning!

To avoid damage to the operator and the door, the operator must only be fitted if

- the operator is undamaged,
- the ambient temperature is -20°C to $+60^{\circ}\text{C}$,
- the altitude of the location does not exceed 1,000 m,
- a suitable protection type has been selected.

Before installation, ensure that

- the operator is not blocked,
- the operator has been newly prepared after a lengthy storage period,
- all connections have been carried out correctly,
- the direction of rotation of the drive motor is correct,
- all motor protective devices are active,
- no other sources of danger exist,
- the installation site has been cordoned off over a wide area.

5. MECHANICAL INSTALLATION

Connecting bolt:

- ▶ Hexagon flange bolts with a minimum strength of 800 N/mm² (8.8) must be used.

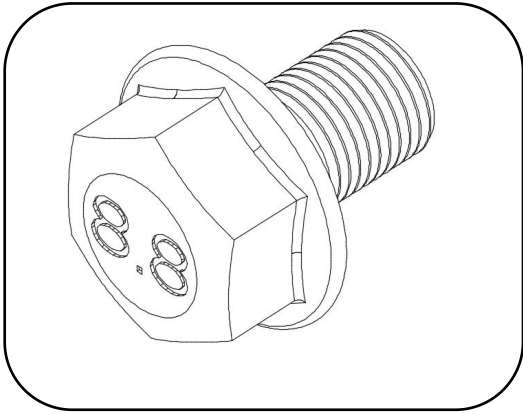

Allowed installation location:

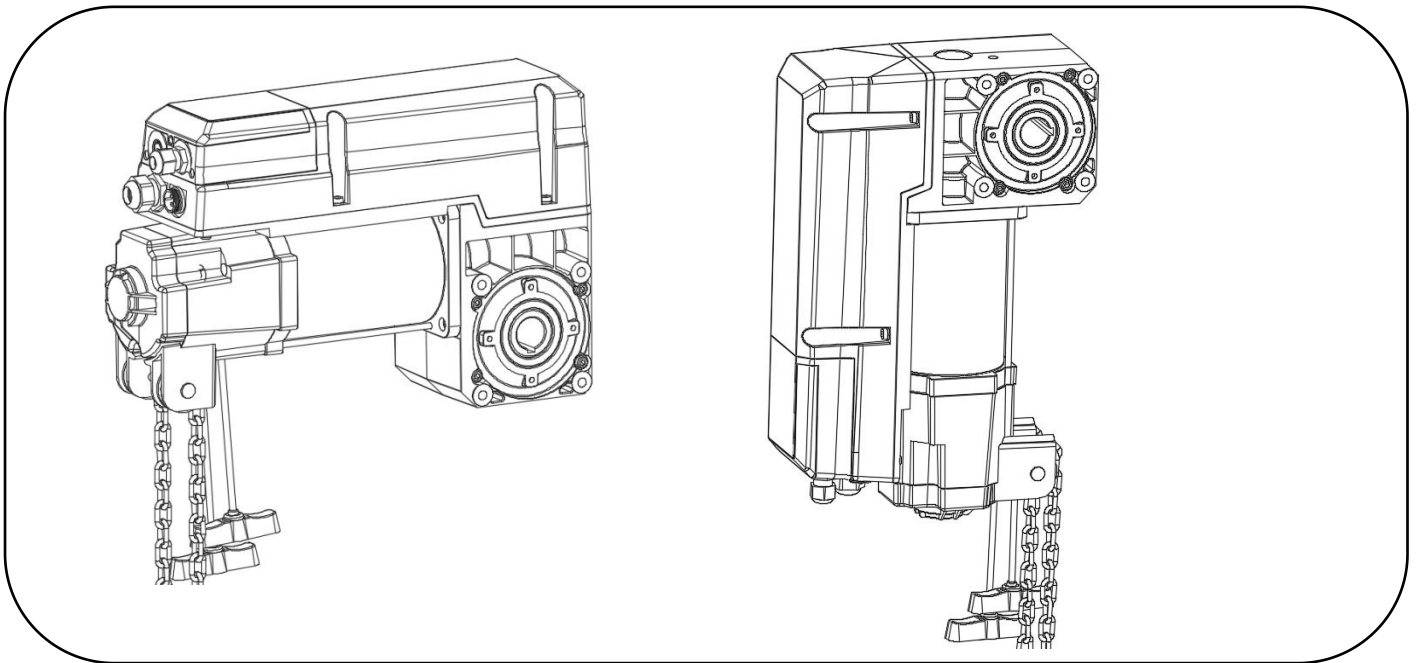

Mounting the accessories:

► Use the provided connection components (①)。

1. M8*12 hexagon flange bolts x 4;

2. Different sizes key pins x 2;

- Check whether the key pin is suitable for the spring shaft on site. (②)

3. Locating ring assembly x 2;

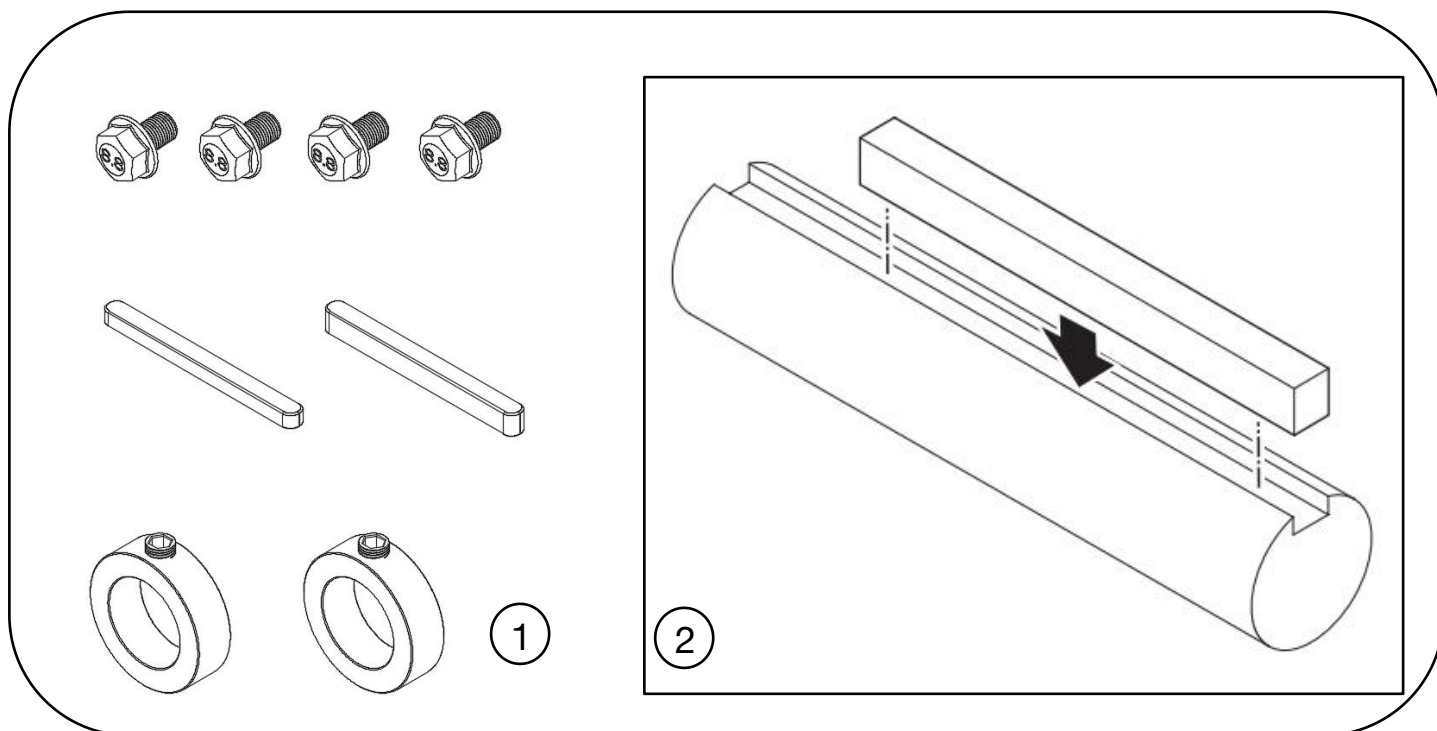

Mounting with the torque support bracket:



Warning!

To avoid damage to the operator and to the door, the operator must be mounted on a console or a torque support bracket so that it is vibration damped.

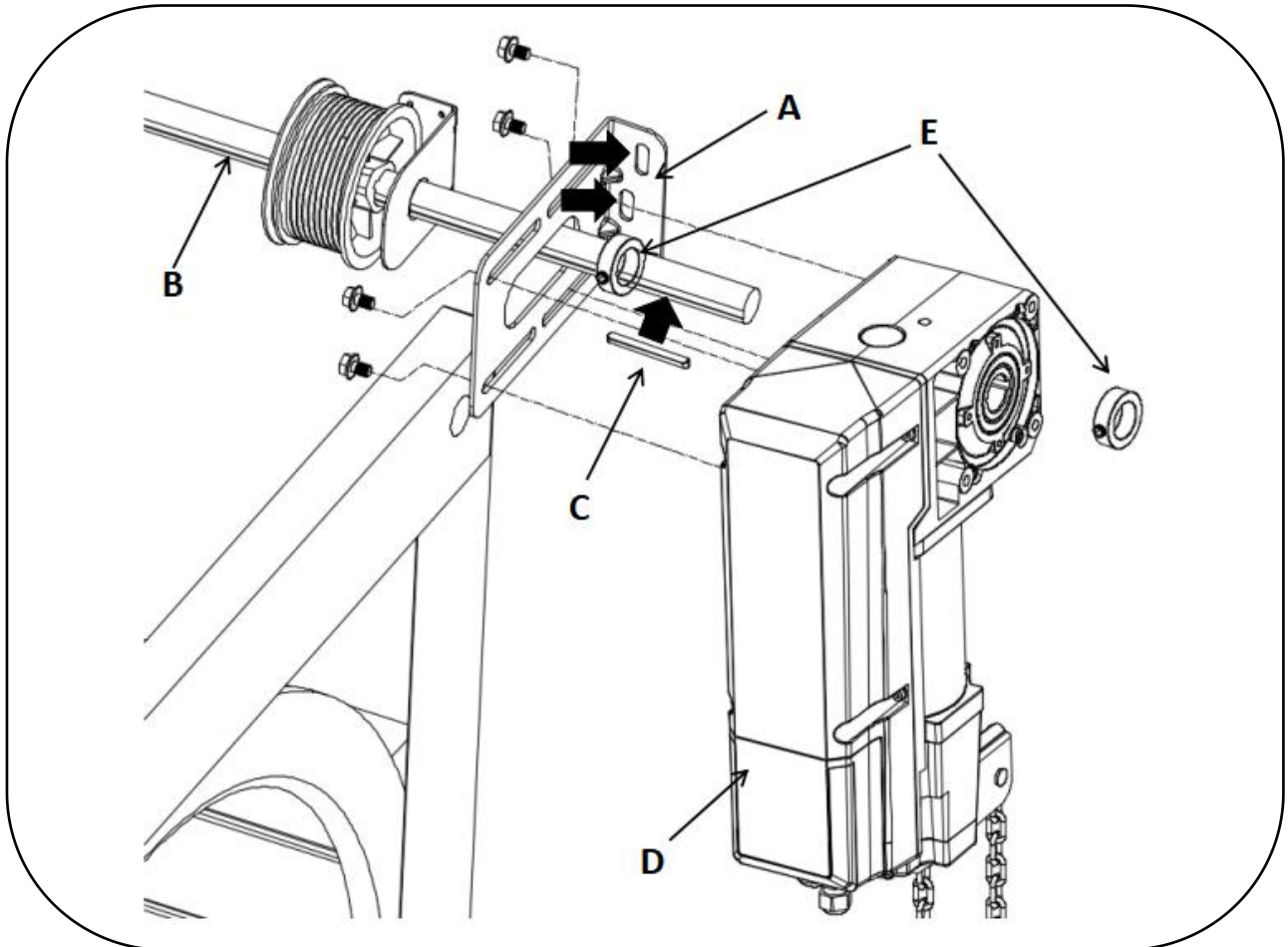

- Fit the torque support bracket/console (A).
- Grease the spring shaft (B) around the operator seating.
- Insert the key pin (C) into the spring shaft (B).
- Place the operator (D) on the spring shaft (B).
- Secure the key pin (C) against any movement.
- The key pin can be secured with two locating rings(E).
- Fix the operator to the torque support bracket with 4 screws.

6. EMERGENCY MANUAL OPERATION (Rapid hand chain operator)

Emergency manual operation is designed for opening or closing the door without power supply. Its activation interrupts the control voltage. Electrical operation is no longer possible.



Warning – Injuries due to incorrect operation!

- Switch off voltage.
- Adopt a secure position.
- For drive units with brake, the emergency manual operation must be carried out against the closed brake.



Warning - Danger of the door dropping!

If you need to apply more than the permissible force of 390N (according to EN 12604/EN 12453) to move the door by emergency manual operation, this indicates a stalling on the drive unit or door. Releasing the stalling may cause the door to drop.

- Adopt a secure position.
- For drive units with brake, the emergency manual operation must be carried out against the closed brake.



Caution – Damage to components!

- Do not move the door beyond the final limit positions.

☞ Pulling the red handle on the left side, the door drive will be powered off, the door can be moved manually. At this time, while operating the door drive again, the digital display will

show **EA** ;

- At this mode, you can close the door by pulling the chain on the left side manually;
- At this mode, you can open the door by pulling the chain on the right side manually;

☞ Pulling the green handle on the right side, the door can be moved with the door drive; At this time, while pulling the chain, the door drive has no response.

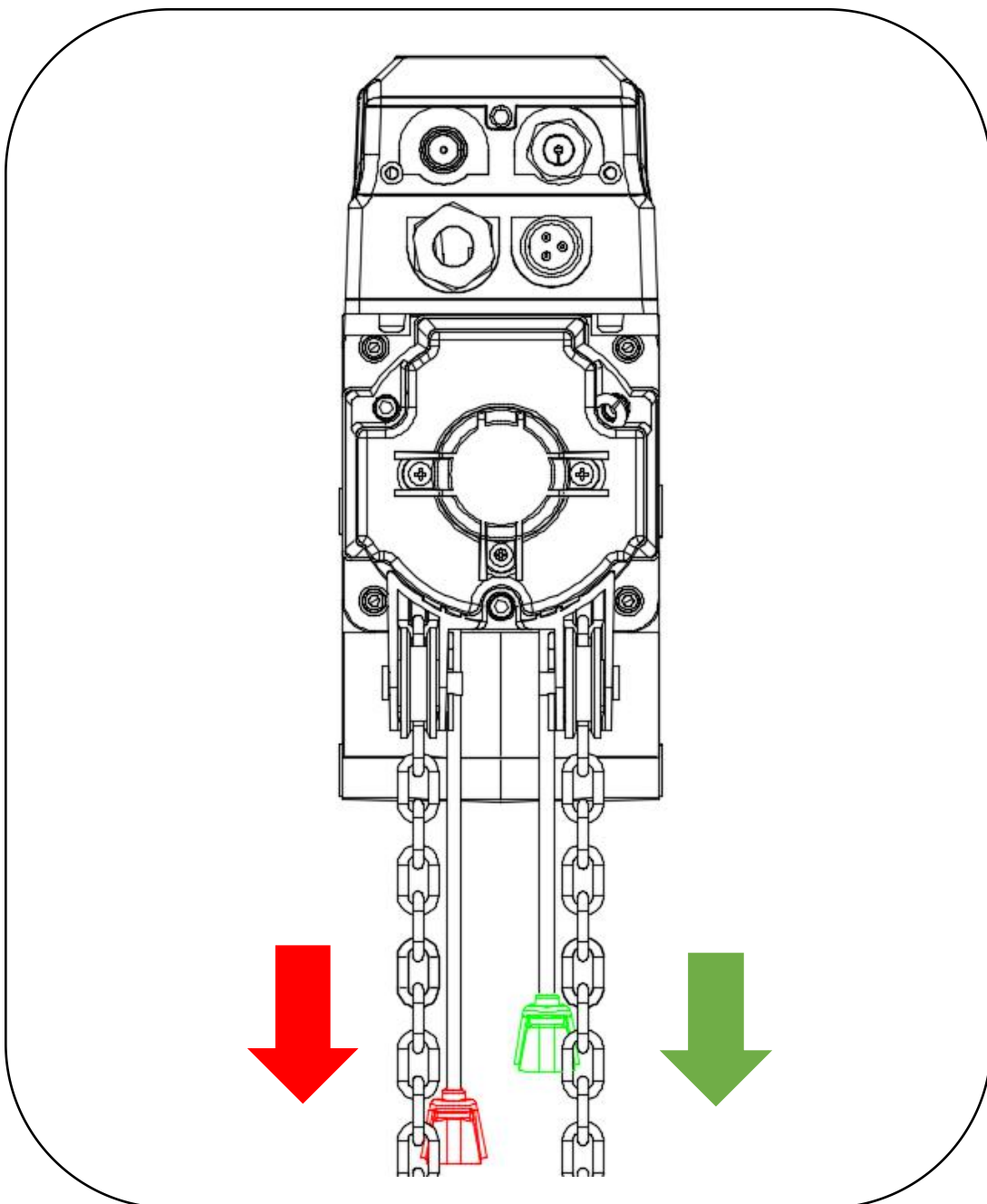

7. COMPLETING COMMISSIONING / INSPECTION

Check the following components and then install all covers.

Gearbox

Check the drive unit for loss of oil (a few drops can be neglected). Protect the output-shaft permanently against corrosion.

Mounting

Check that all connection elements (consoles, torque mounts, screws, locking rings, etc.) are secure and in proper condition.

Electrical wiring

Check the connection cables and cabling for damage or crushing. Check that the screw connections and plug connections are fitted properly with a good electric contact.

Emergency manual operation

Check the function with the power disconnected. Perform the check only between the final limit positions.

Limit switch

Check the final limit positions by opening and closing fully. The safety area must not be approached.